

Stipite

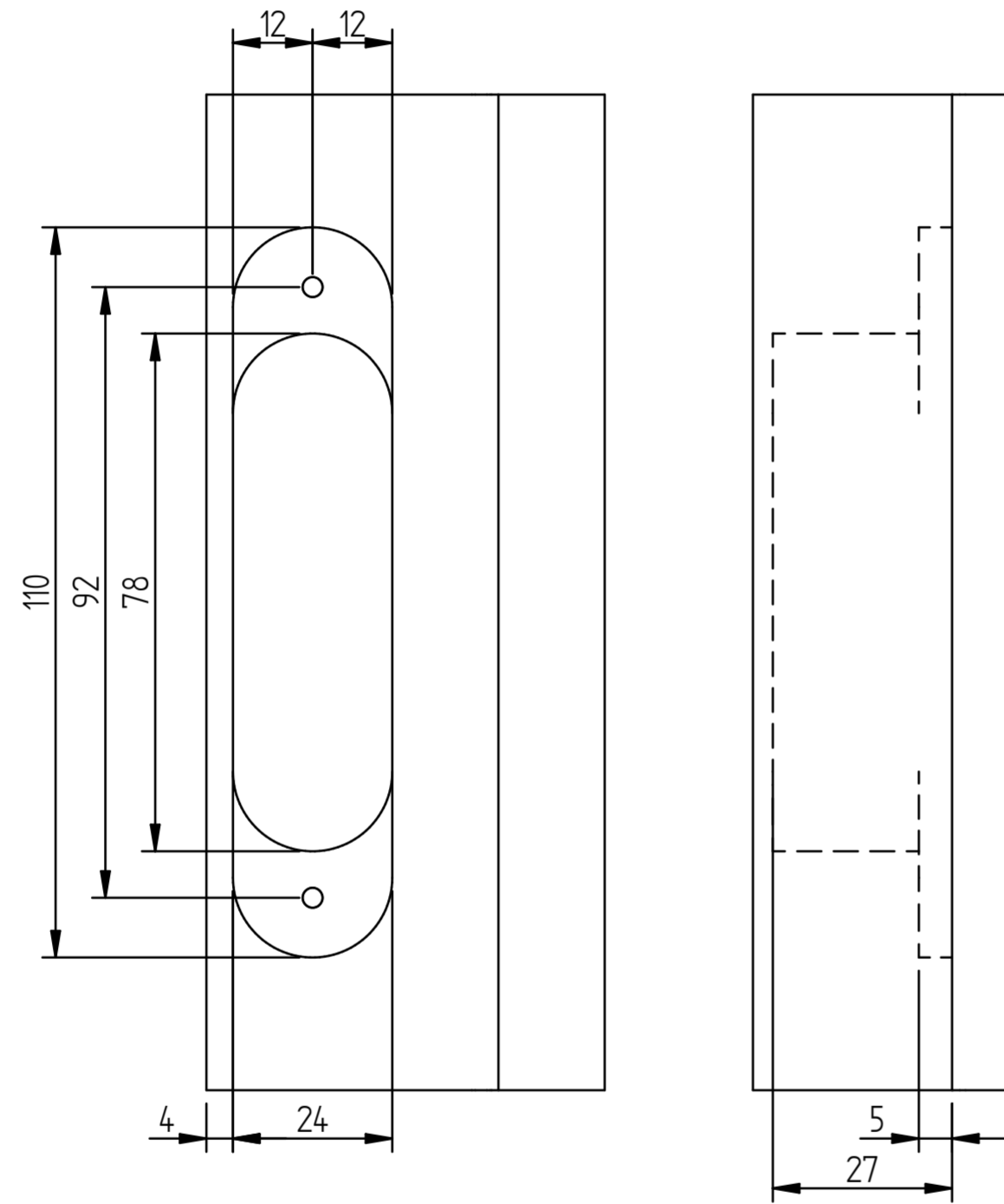

Porta

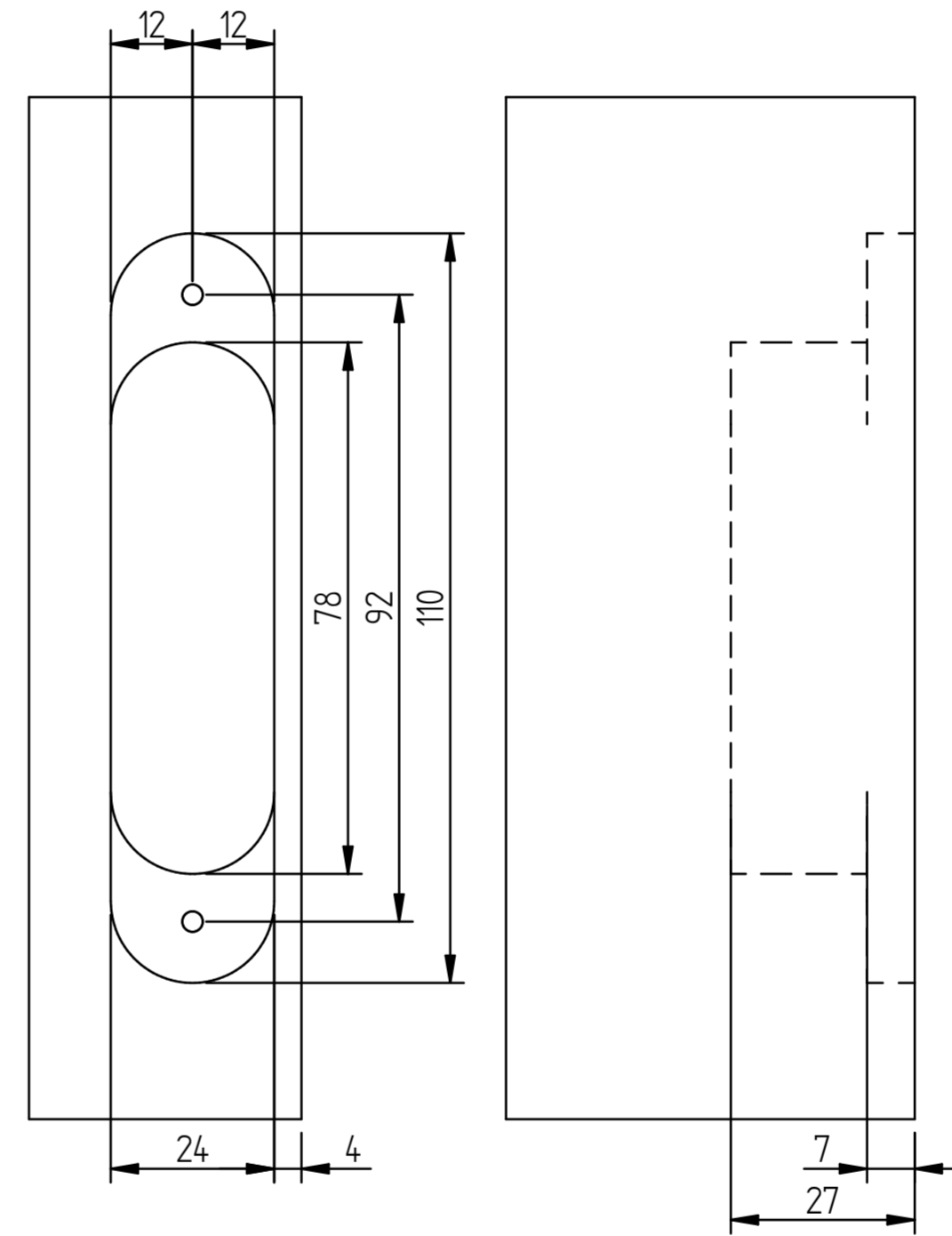

Tolleranze non indicate secondo UNI EN 2768-1:1996 Classe:M		Stato disegno: 0	
Anselmi MEMBER OF HANSONVEIK		TITOLO	
Saura A.		Schema fresature	
Disegnato		Controllato	
Approvato		Formato	
A2		Data 1ª emissione	
09/09/2022		Scala	
1:1		Data revisione	
09/09/2022		Revisione	
00		Nome File	
Schema fresature AN 180 3D.dft		Peso	